

# Owner's Manual

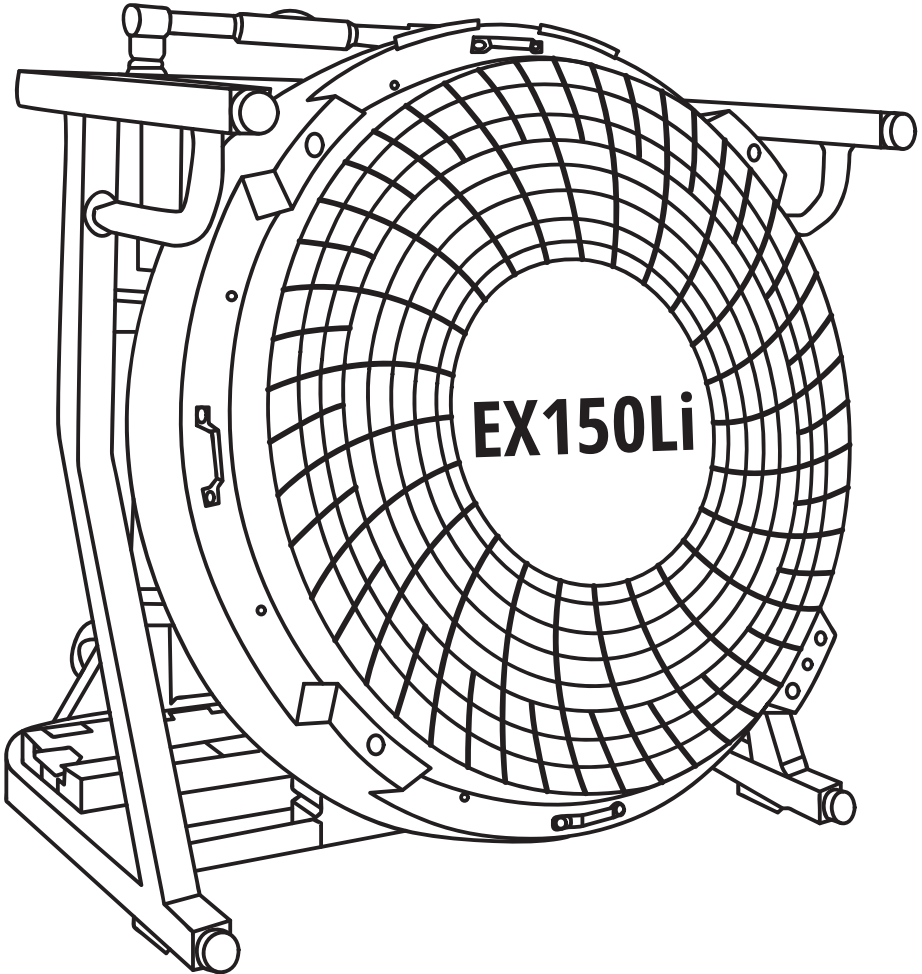

## ALL PURPOSE-BATTERY VENTILATOR

# CONTENTS

<b>Introduction</b> .....	3
About Euramco .....	3
Warning Labels and Safety Instructions .....	4
Safety Checklist .....	5
<b>Unit Description</b> .....	5
Parts List .....	5
Technical Specifications .....	6
Dimensions .....	6
Main Interface .....	7
Plug Type .....	8
Adjusting Angle .....	9
<b>Operational Modes</b> .....	10
AC Operation .....	10
DC Operation .....	10
- Connection of Battery Pack .....	10-11
- Battery Operation Procedures .....	12-13
- Run Time .....	13
- Charging Procedure .....	14
- The Fuel Gauge .....	15
- Status Indicator Lights .....	16
- Battery Pack Protection .....	16
<b>Storage/Transport Modes</b> .....	17
- Cord Storage .....	18
- How to Store Batteries .....	18
- Cold Weather Operation .....	18
- Factors that affect Battery Life .....	18
<b>Maintenance and Disposal</b> .....	19
<b>Accessories</b> .....	19
<b>Certification</b> .....	20
<b>Declaration of Conformity</b> .....	21

## Introduction

---

Congratulations on your purchase of the high-end ventilator RAMFAN EX150Li.

### **WARNING!**

Read this manual before starting for the first time!

You now own an industrial ventilation unit that offers endless possibilities. Before using, make sure that no damage was done to your ventilator during transport. If this is the case, do not use the product and immediately contact your authorized Euramco dealer.

For your own safety and that of others, please read this instruction manual carefully before using the unit.

Anyone involved in installing, operating or servicing the EX150Li must:

- Be a qualified, authorized professional.
- Strictly follow the instructions in this user manual.

Please take the time to read this manual carefully and thoroughly before operating the ventilator. You should have a good knowledge of its operating conditions and all pertinent product information.

After you have become familiar with this manual, we recommend that you keep a copy for future use. All the information found in this manual is subject to change without notice. Euramco reserves the right to modify and upgrade its range of products, with no obligation to integrate these changes into products already sold.

If any questions arise concerning any of the information in this manual, Euramco Customer Service must be consulted:

Euramco Group  
2746 Via Orange Way  
Spring Valley, CA - 91978  
Ph 619.670.9590  
Fx 619.670.7345  
Toll Free: (800) 472-6326  
theteam@euramco.com  
www.euramco.com

## About Euramco

---

Euramco Group is a leading manufacturer of portable ventilation solutions for the world's toughest job sites, with a primary focus on rotating machinery, engineered for superior fluid dynamics, and developing innovative industry-specific drive and control solutions. Euramco Group sells to defense, firefighting, hazardous area, and commercial safety markets worldwide through five locations globally.

# Warning Labels and Safety Instructions

This is the safety-alert symbol. 

When you see this symbol on your ventilator or in this manual, be alert to the potential for personal injury or damage to your equipment. Be sure you understand all safety messages and always follow recommended precautions and safe operating practices. Important safety information is presented in this section and throughout the manual:

- Electrical shock hazard. Do not open the unit.
- DO NOT START with signs of visible damage.
- Ventilator is not intended for operation in explosive atmospheres.
- Wear ear protection when close by.
- Keep body parts and loose objects away from in take of ventilator.
- Do not move ventilator while in operation.
- Operate and repair by trained personnel only.
- Always use grounded plug and properly ground AC power receptacle.
- Heat sink becomes hot during charging to some extent. DO NOT touch. Do not place items over heat sink area.
- Use with approved, good condition extension cord with the ground connector:

Wire Gauge Requirements per ft (m)	
0-150 ft (0-50m)	AWG 14 (2.5 mm <sup>2</sup> )
>150 ft (> 50m)	AWG 12 (4 mm <sup>2</sup> )

	<b>KEEP FINS CLEAR</b>	<b>HOT SURFACE! DO NOT TOUCH! DO NOT PLACE ITEMS OVER HEAT SINK AREA!</b>
---	--------------------------------	---

<b>DANGER</b>		
<b>HIGH VOLTAGE DO NOT OPEN</b>		
No User Serviceable Parts		
	<b>CAUTION!</b>	
		

## Safety Checklist

---

- ✓ Always purchase from a Euramco's authorized dealer to ensure you are getting real RAMFAN products, a full product warranty, and the best customer service.
- ✓ Flexible electrical cables connected to the equipment may not be used when damaged
- ✓ If you are unsure if the equipment is unsafe or if there are signs indicating that the equipment is defective or damaged, report it and do not use it.
- ✓ Check if the connectors, cables and its connections are in perfect condition.
- ✓ Do not use the equipment until the equipment has been fully assembled and inspected for correct performance in accordance with the Owner's Manual.
- ✓ Fully charge the batteries before the first use! Safeguard your battery to ensure continued high performance. It should be recharged after each use.

## Unit Description

---



- The EX150Li is a multi-purpose 18"/46 cm ventilator powered by battery(s) or 90-250V single phase, 50-60Hz AC power source. Its multipurpose frame can be configured for PPV, smoke ejector or ducted ventilator use in both normal, horizontal and hanging positions. The ventilator can be tilted from 0-30° within the frame in PPV mode.
- The motor controller and batteries are water-resistant, IP66 rated.
- The motor is a variable-speed BLDC motor controlled by a microprocessor integrated with a power supply, dual battery chargers and an LED light driver.
- The EX150Li will run with one or two 52V 8Ah Lithium Ion Battery Packs. The batteries may be swapped during operation.
- AC voltage can be applied while running on batteries and the ventilator will auto-switch to AC power. Conversely, the AC power can be removed, and the unit will auto-switch to battery power, if enough charge remains to power the ventilator.
- The integrated battery chargers will charge one or two fully discharged battery packs in 6 hours or less.
- LED scene lights are integrated into the ventilator shroud and have a 3-intensity infinite switch knob: high, low and off. Turn to change. The LED knob selects the scene lights output level in a row. Clockwise Progression: Off ► Full ► Half ► Off.
- A Control Panel on the top of the unit controls all functions.

## Parts List

---

Qty	Description
1	Ventilator EX150Li with Wheel Kit assembled
2	Lithium-ion Battery Pack M1-52V 8Ah
1	Power Cord

## Technical Specifications

<b>Model</b>	<b>EX150Li 18" (46 cm)</b>
Motor	1.9hp (1.4kw)
Order #EL6500	EX150Li with wheel kit assembled (1), 52V 8Ah battery (2) and power cord (1)
Runtime @ Full speed	DC: 45 min DC Max: 30 min AC: Unlimited
AC Input	Multiple plug options available
Battery System	52V Lithium-Ion, 832Wh, 16Ah
IP Rating (Motor/ Battery System/Controller)	IP66 / IP66 / IP66
Weight	2 packs 71 lbs (32 kg) Without Battery 58 lbs (26 kg)
Dimensions (h x w x d)	23 x 21 x 19 in / 58 x 53 x 48 cm
Approvals	 
AMCA Verified Airflow in DC Power Supply	12,377 cfm (21,029 m <sup>3</sup> /hr)
AMCA Verified Airflow in AC Power Supply	11,896 cfm (20,211 m <sup>3</sup> /hr)

## Dimensions



# Main Interface

## Control Panel:

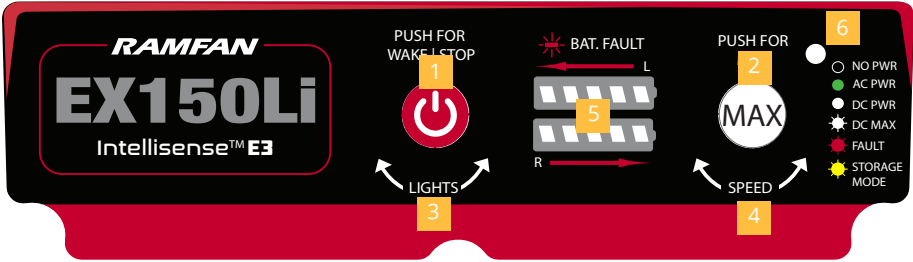

Number	Symbol	Indicate Function
1		Wake Button / Emergency Stop Button Press and hold WAKE button to start.
2		Maximum Speed (DC) Button Press MAX button for 2 seconds.
3		LED Scene Lights On, off, on high or on low.
4		Speed Control Controlled operation from 0 to full speed
5		Battery Status LED Lights
6		Ventilator Status LED Lights See table below for details.

Color	Status	Description
Off	NO PWR	Power is off
Green (Solid)	AC PWR	Ventilator is running on AC Power Supply
White (Solid)	DC PWR	Ventilator is running on DC Power Supply
White (Flashing)	DC MAX	Ventilator is running on Maximum speed - DC Power Supply
Red (Flashing)	FAULT	Fault on the ventilator
Yellow (Flashing)	STORAGE MODE	Storage/Transport Mode

## Plug Types

The EX150Li is suitable for worldwide applications. A voltage converter is not needed. The unit includes a simple removable cord that allows the unit to operate up to 250 VAC:

Mainly used in	Type	Order #
USA, Canada, Mexico and Japan	B	EL-CUS-4762
Germany and France (and most European countries)	E/F	EL-CEU-4762
United Kingdom, Ireland, Malta, Malaysia and Singapore	G	EL-83070-4762
Australia, New Zealand, Papua New Guinea and Argentina	I	EL-84040-4762
China	I	EL-84640-4762

If it becomes necessary to use a power cord with another plug standard, order the power cord that matches the electrical requirements of the country or area. The physical adapter for the outlet is interchangeable for use in different countries and allows you to swap the cable yourself into the socket.

This is an overview of electric plugs that are in use around the world. If you need a special solution, just inform your local Euramco representative about the specific.

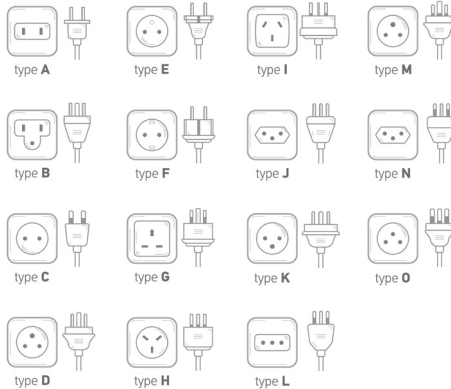

If you must change the power cord, please disconnect the cord from the electrical outlet located on the back of the ventilator, as shown below, and replace with another:

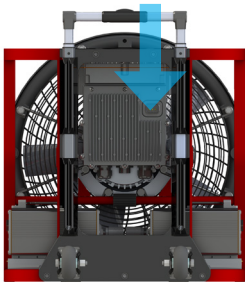

### How to Install and Remove Power Cable:

- Cable snaps into place, easy one hand usage.





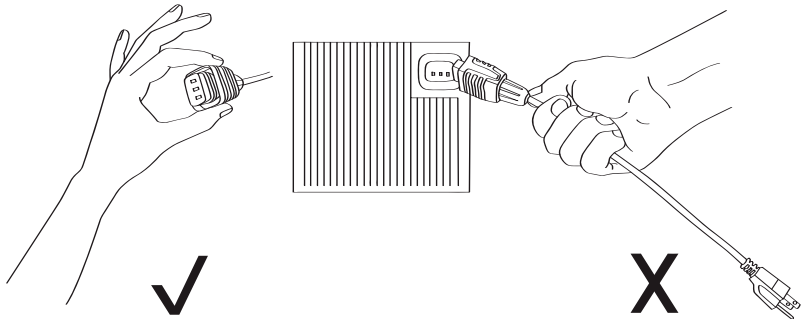

Pull the plug out itself, never by the cord or by wiggling it out of the outlet.

## Adjusting Angle

---

To adjust the ventilator angle to suit the desired position, unscrew the tilt adjustment knob and adjust it at the desired angle upwards and then lock it in position by tightening the knob. The shroud can pivot upwards to a range of 30°.

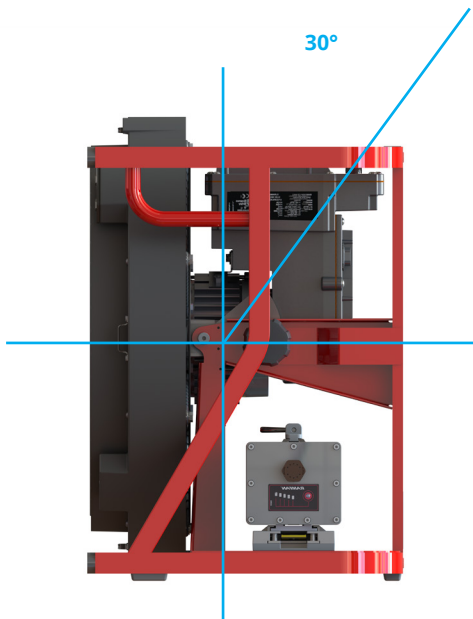

30°  
Tilting Angle



## Operational Modes

---

### AC Operation

---

- Input Voltage. 90-250VAC, 50/60Hz
- The ventilator is capable of operating seamlessly in countries that supply electricity at either 120V AC/60 Hz or 240V AC/50 Hz without manual adjustments by the user.
- Operation out of these limits can damage electrical components and will void the warranty.

1. Connect the fan to an AC power source.
2. Status LED Light will automatically turn green, displaying the status “Ventilator is running on AC Power Supply”.
3. Start the ventilator by using the Speed Control knob to the desired speed.  
Note: You can keep the batteries on their location without charging the battery. Battery Indicator Lights will turn off because there is no battery charging when ventilator is running on AC.
4. When the fan is powered off, Status LED Light will automatically turn off after 1 hour and the battery Indicator Lights will redisplay battery charge level of each battery pack detected. The ventilator will begin charging the battery packs after 60 minutes of idle time.
5. Battery Packs do not charge while ventilator is running.

### DC Operation

---

#### Connection of Battery Pack

---

- Plug the ventilator connector cable (blue) into the battery connector:

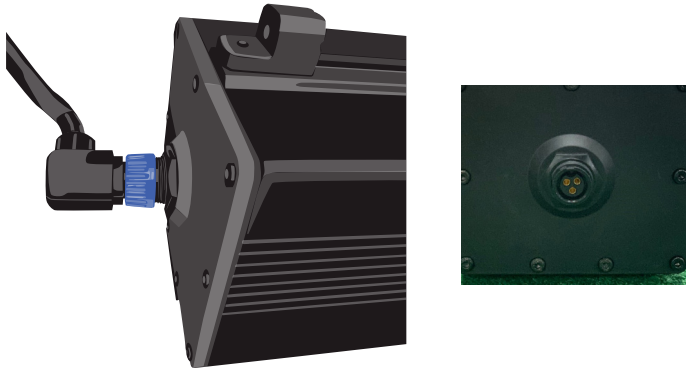

- Set the installation index on the battery with the cable, lining up with the cable connector.
- Press the connector lock and rotate the blue piece clockwise (a quarter turn to the right) in the most careful way possible.
- Align the edge of the battery pack with holder under the red line where it says, “Align battery EX150Li” and firmly slide the battery in the direction of the arrow as shown in the illustration until a loud click is heard.

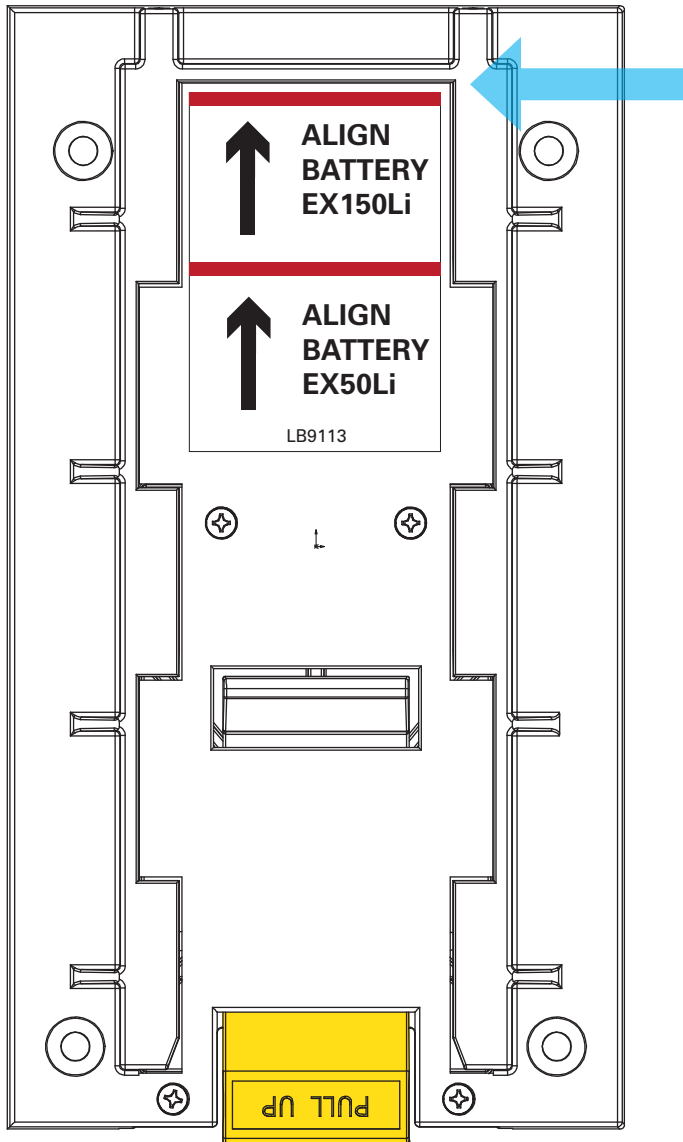

- Gently pull up the yellow handle to remove the battery from the holder.

# Battery Operation Procedures

---

Please full charge battery before first use

## Using One Battery

- The EX150Li allows the option of using one or two battery packs.
- When using one battery, simply plug the battery into either one of the two battery connectors (left or right).
- Be sure to secure the unused battery connector by placing electrical tape over the contacts.
- When the system is powered using one battery, the battery indicator light bar on control panel will only emit light for one battery, when the system is powered on.



## Using Two Batteries

### • ***The EX150Li offers a true redundant dual battery system.***

- When using two batteries of identical charge level, batteries are connected in parallel to increase significantly the total runtime and airflow performance.
- When using two battery packs, each pack functions independently and is isolated from the other so that if one pack should fail (open circuit, short-circuit, or become discharged) the other battery will provide power to operate the system.
- When using dual batteries, it's important that both batteries be of the same charge level and ideally of the same age and condition.
- It's normal for one battery to discharge slightly more than the other. This is the nature of a truly redundant isolated battery system.
- The battery that has the higher voltage will discharge at a faster rate (until its voltage equals the other battery).
- We recommend that use both batteries on the Same State of Charge (or at least as close as possible). If this is not possible, the controller will eventually bring batteries to a balanced charge level.
- To keep battery packs healthy for long-term use, a simple implementation of cell-balancing, internal to the battery pack, includes a FET placed in parallel with each cell and controlled by a comparator for simple voltage based algorithms that turn-on the bypass FETs during the onset of voltage differences, controlled by a microcontroller for more complex and effective algorithms that can work continuously regardless of variations of voltage differences.

## Battery Operation Procedures

---

- When AC is disconnected and Speed Control is off (speed = 0), the controller and battery(s) will enter a sleep mode to conserve the battery power after 60 minutes of no activity.
- To wake the ventilator, push and hold WAKE | STOP Button  on Control Panel. Battery Status LED Light will show white solid for the status. The unit will return to sleep mode if not used within 10 minutes.
- The ventilator starts at the lower speed = 0. Speed will vary by 11 levels - from 11 (highest) to 0 (off). Turn clockwise to increase speed. At level 11 (the highest), if keep turning the control knob clockwise, the speed will not change, it will stay at highest speed all the time. To slow down, turn counterclockwise.
- If you want to increase the speed, push and hold the MAX Button  Ventilator Status LED Light will flash white for the status. Remember that this will only work when 2 batteries are connected to the ventilator and when it is operating exclusively on DC current source (battery).
- The ventilator will operate on one or two battery pack(s). If two battery packs are used simultaneously, they discharge evenly.
- To STOP the ventilator, push and hold WAKE | STOP Button  on Control Panel. Battery Status LED Light will be unlit.
- Battery(s) may be swapped for charged batteries at any time.
- Reduce run speed to minimum required to increase runtime.

## Run Time

---

Run time refers to how long the ventilator on battery power will last under a given load. We will assume both batteries have full charge beforehand and also 100% efficiency (Read "Factors that affect Battery Life" section):

	2 Batteries	Speed Level Knob
At maximum speed	45 minutes	11
At maximum speed and DC Max button activated	30 minutes	Max button activated 

## Charging Procedure

---

Make sure the battery pack is connect correctly into the ventilator, as described above in **“Connection of Battery Pack”**.

- The next step is to leave the ventilator off. During charging, the battery indicator lights will flash. The battery charge level can be recognized by the number of lights that are constantly lit.
- If both batteries and AC are connected, the batteries will begin charging after 60 minutes of idle time. If only one single battery is connect, the battery will begin charging after 120 minutes of idle time.
- Indicator lights will show charge state during charging. Charging should complete in about 5 hours, with the Battery Status Indicator lights turning green and all the five Fuel Gauge lights on the battery turning red. Should the Speed Control be turned counterclockwise on during the charge, charging will stop, and the ventilator will start. Charging will begin again after 15 min of idle time.
- After charging is complete, the chargers will maintain the battery(s) by keeping the ventilator connected to AC.
- While charging, the battery status LED lights will strobe, as well as the battery charge indicator status lights located on the battery itself. The batteries will be disconnected at the end of their charge automatically. At the end of charging, the current power is discharging for 5 minutes and then lights will be turned off.
- If all the Fuel Gauge lights are flashing, this indicates an error condition.



# The Fuel Gauge

The Battery Fuel Gauge provides battery status information using five red LEDs.

Press the Fuel Gauge button to display the lights. The fuel gauge lights will remain lit for approximately five seconds.

The numbers represent each LED and the grid is how they're laid out:

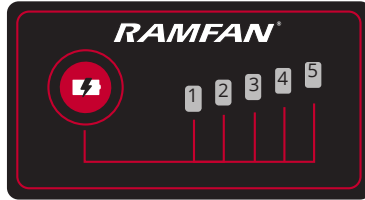

Fuel Gauge Lights	Diagnosis	Solution
LEDs 1-5: Red Solid	Remaining Run Time	Continue Working
LED 1: Red Flashing LEDs 2-5: Off	Less than 13% run time left	Charge Pack
LEDs 1-5: Red Flashing	Battery Temperature too high	Allow Battery to Cool

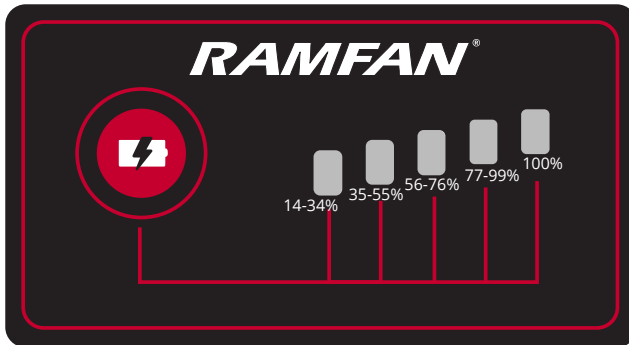

Less than 13% if bottom light is flashing

## Battery Status Indicator Lights

On the control panel there are 2 sets of lights: on the top side of the battery lights indicate the charge level in the battery attached to the left side of the ventilator, on the bottom side of the battery lights indicate the charge level in the battery attached to the right side of the ventilator.

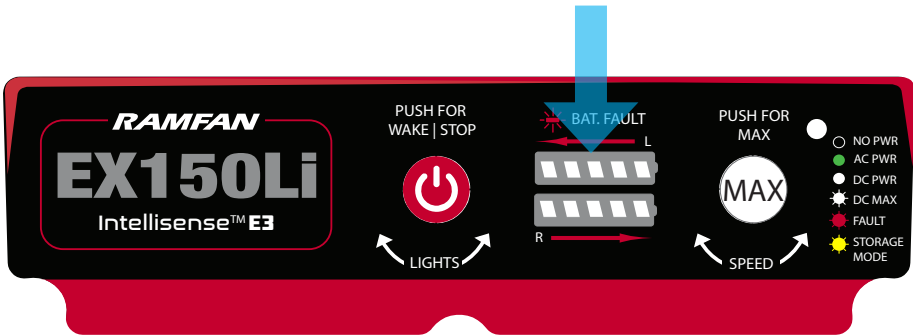

If the battery is charging, the green indicator lights will horizontally scroll from left-to-right, turning solid green when the battery is fully charged.

If the ventilator is running on battery power, the estimated remaining battery time is shown.

If all the lights flash red, this indicates that the battery has failed and the battery must be replaced.

## Battery Pack Protection

- To protect itself from damage and extend its life, the battery pack's intelligent circuit monitors current draw and temperature. In extreme situations, the battery pack will turn OFF the ventilator if the current draw becomes too high. All the fuel gauge lights will flash.
- Under extreme circumstances, the internal temperature of the battery could become too high. If this happens, the fuel gauge lights will flash in an alternating pattern and the tool will not run.
- While a battery undergoes a charge cycle, its temperature rises. To prevent grid corrosion and eventual battery failure, allow the battery to cool down in between charging and discharging.



## Storage/Transport Modes

- Make sure the power cord is disconnected before activate the Storage/Transport Mode and 1 or 2 battery pack(s) are connected to the ventilator (at battery mode).
- To activate Storage/Transport Mode, press and hold the WAKE|STOP and the MAX buttons at the same time for 8 seconds or until the top Status LED Light switches to yellow flash mode (STORAGE MODE).
- Motor automatically runs a very low rpm until it reaches 30% of SoC. Unit will turn off automatically when it is done. Setting the speed to off will also exit storage/transport mode.
- The Storage/Transport Function is disabled when the unit is running in AC mode.

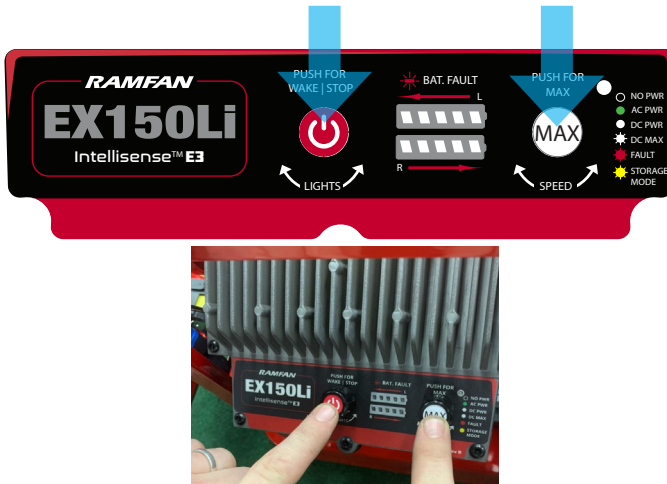

### Transport Mode (Battery)

All lithium ion cells and batteries must be shipped at a state of charge (SoC) not exceeding 30% of their rated capacity, according to IATA Dangerous Goods Regulations (DGR).

Due to this requirement, the ventilator is equipped with a built-in "Transport Mode" function.

When this function is activated, the motor automatically runs a very low rpm to let the battery discharges until it reaches 30% of SoC. The controller monitors the battery voltage and shut down the motor when this SoC level is reached.

### Storage Mode (Battery)

The Storage Mode is designed to keep your battery maintained during long term storage.

Store lithium batteries at around 30% charge level. The 30 percent charge allows a stable condition even if it means a level of self-discharge. Some reserve charge is necessary to keep a battery and its protection circuit operational during long periods of storage.

When Storage Mode is activated, the motor automatically runs a very low rpm to let the battery discharges until it reaches 30% of SoC. The controller monitors the battery voltage and shut down the motor when this SoC level is reached.

## Cord Storage

---

After use, store the power cord on the holder on the side of the fan, where there is a label representation of how to store it:



## How to Store Batteries

---

Temperature range for battery storage:

- Store less than 1 month: -20°C to +60°C (-4°F to +140°F)
- Store less than 3 month: -20°C to +45°C (-4°F to +113°F)
- Store less than 1.5 year : -20°C to +25°C (-4°F to +77°F)

Temperature range for discharge: -20°C to +45°C (-4°F to +113°F)

Temperature range for charge: 0°C to +40°C (+32°F to +104°F)

Maximum non-operational relative humidity for storage: 90% RH

## Cold Weather Operation

---

RAMFAN Lithium-Ion battery packs are designed to operate in temperatures below freezing.

A "cold-soaked" battery may not power a unit. To obtain full power, warm up a cold-soaked battery at room temperature before charging.

## Factors that affect Battery Life

---

- Battery packs will last significantly longer when run in pairs; there will be a lower amp draw on each cell.
- Similar to a mechanical device that wears out faster with heavy use, the Depth of Discharge (DoD) determines the cycle count of the battery. The smaller the discharge (low DoD), the longer the battery will last. If at all possible, avoid full discharges and charge the battery more often between uses. Partial discharge on Li-ion is fine. There is no memory and the battery does not need periodic full discharge cycles to prolong life. Battery(s) will need to be replaced as they age.
- Keep the ventilator attached to AC while not being used. This will keep them charged and lengthen their service life. An idle battery will slowly lose charge and possibly become unusable.

## Maintenance and Disposal

---

- DO NOT disassemble the ventilator for maintenance reasons.
- Do not loosen screws on control box without contacting Euramco customer service. They are torqued to a setting to achieve water tightness. Clean ventilator periodically to remove accumulated dust or particles from ventilator guards.
- Assembly screws are torqued to a specified value to achieve water tightness. Completely unravel power cord and place unit on a flat, stable surface. Clean ventilator periodically to remove accumulated dust or particles from ventilator guards, impeller blade and heat sink in rear of controller (ribbed). Use only biodegradable detergents. If power washing, avoid controller housing especially gaskets and control panel.
- Contact factory for replacement parts and installation instructions. To order spare parts call Euramco Group **+1.619.670.9590** or **theteam@euramco.com**
- Always dispose of your battery pack according to federal, state and local regulations.
- Even discharged batteries contain some energy. Before disposing of, use electrical tape to cover the terminals to prevent the battery pack from short circuit.
- Properly dispose of battery packs when necessary. Contact your local hazardous materials e-waste collection department for details or proper disposal of rechargeable batteries.

## Accessories

---

### 1. Swappable 52V Li-Ion Battery Pack

Spare Battery (recommend ordering 2)

Order # M1-52V



### 2. Vehicle Mount Kit

Custom mount that perfectly fits ventilator

Order # EL610K



### 3. EX50Li Mister

Order # EL8111



### 4. Hi-Expansion Foam Adapter

Foam adapter converts EX150Li into a high expansion foam generator

Order # HI-X18



### 5. Convert to Confined Space Rescue Fan

18"/46cm duct (16.4'/5m length)  
Order # FDT-185MSR



18"/46cm duct (32.8' / 10m length)  
Order # FDT-181MSR

### 6. Bolt-on Rubber Foot (Set of 4)

Rubber foot (Set of 4) + Screws for EX150Li frames





## AMCA



Euramco Safety Inc. certifies that the portable PPV Blowers shown here are licensed to bear the AMCA SEAL.

Euramco Safety Inc. certifies that the Portable PPV Blower shown below is licensed to bear the AMCA Seal. The ratings shown are based on tests and procedures in accordance with AMCA Publication 211 and comply with the AMCA Certified Ratings Program.

### Why We Use AMCA

AMCA, The Air Movement and Control Association International, has been in existence for nearly 80 years and is the world's only recognized authority for the development of standards and measurement of air movement.

*Our commitment to AMCA Certification is your verifiable assurance that every RAMFAN PPV Turbo Blower will perform exactly as specified.*

## SPECIFICATIONS AND PERFORMANCE RATINGS

MODEL	SIZE		HP	DIMENSION (HxWxD)		MOTOR MFG/MODEL N°	WEIGHT		RPM	SETBACK		ANGLE	AIRFLOW @ FULL SPEED		POWER SUPPLY
	in	cm		in	cm		lbs	kg		ft	m		tilt	cfm	
EX150Li	18	46	1.8	23x21x19	58x53x48	Euramco EM-E1020	58	26	3550	16	4.9	11°	11,896	20,211	AC
EX150Li	18	46	1.8	23x21x19	58x53x48	Euramco EM-E1020	58	26	3600	16	4.9	11°	12,377	21,029	DC

**Performance certified is for installation type A - Free inlet, Free outlet.**

**Performance ratings do not include the effects of appurtenances (accessories).**

RAMFAN's fire fighting PPV Series outperforms larger blowers in their class with their precision balanced TurboForce Impellers that maximize airflow. These PPV blowers have proven to be effective in controlling airborne contaminants, replacing interior air, removing heat and supplementing fixed ventilation systems. By pressurizing properly and controlling the resultant flow path, these changes occur very rapidly. This is accomplished by using these specialized blowers with the power and velocity to pressurize the interior of a structure or building.

August 2019



Euramco Group

2746 Via Orange Way | Spring Valley, CA 91978 USA | (800) 472-6372 | (619) 670-9590

WWW.EURAMCO.COM

PROUDLY MADE IN CALIFORNIA



# Declaration of Conformity

## DECLARATION OF CONFORMITY BATTERY POWERED FANS

**Year of Manufacture:** 2019

**Manufacturer:** Euramco Safety, Inc.  
2746 Via Orange Way  
Spring Valley, Ca. 91978 USA

**Equipment Description:** EX50Li – 18"/46cm Battery Powered PPV, Variable Speed, 115V / 230V  
(EL5500 / EL5500-230)  
EX150Li – 18"/46cm Battery Powered PPV, Variable Speed, 85 – 250 V  
(EL6500)

**European Directives:** 2006/42/EC – Machinery Directive  
2014/35/EU – Low Voltage Directive  
2014/30/EU – EMC Directive  
2011/65/EU – RoHS - Reduction of Hazardous Substances

**Standards to which this Conformity is Declared:**  
BS EN ISO 13857:2008 – Safety Distances  
ISO 12100:2010 – Safety Machinery  
BS EN 61000-6-2:2005 – EMC Immunity for Industrial Environments  
BS EN 61000-6-4:2007+A1:2011 – EMC Industrial, Generic Emissions  
UL 508 – Industrial Control Equipment  
UN 3481 – Lithium-Ion Batteries when **Packed with Equipment**

Euramco Safety, Inc. hereby declares that the equipment described above conforms to the relevant Essential Health and Safety Requirements of the European Machinery Directive **2006/42/EC** and The additional Directives and Standards listed above.



**Euramco  
Group**

  
\_\_\_\_\_  
Jack Simmons  
QA & Engineering Manager

11/13/2019  
\_\_\_\_\_  
DATE







SM-EX150U REV C  
121719

**USA**

2746 Via Orange Way  
Spring Valley, CA 91978 USA  
Toll Free: (800) 472-6326  
Phone: +1 (619) 670-9590  
Fax: +1 (619) 670-7345  
theteam@euramcosafety.com

**LUXEMBOURG**

1 Rue Edmond Reuter,  
5326 Contern, Luxembourg  
Phone: +352-621377200  
Fax: +352-26008056  
theteam@euramcosafety.com

**MIDDLE EAST – UAE**

Jebel Ali FTZ, Dubai  
Phone: +1 (619) 670-9590 x114  
Fax: +1 (619) 670-7345  
theteam@euramcosafety.com

**CHINA**

A11, No. 1 Jinx Road  
QingshuiPu, Zhenhai, Zhejiang  
Ningbo, China 315221  
Phone: +86-574-87979390  
Fax: +86-574-87979391  
saleschina@euramcosafety.com